



为您的产品保驾护航

PRODUCT DATASHEET

Miniature Fuse

JFS Series, Time-Lag Fuse

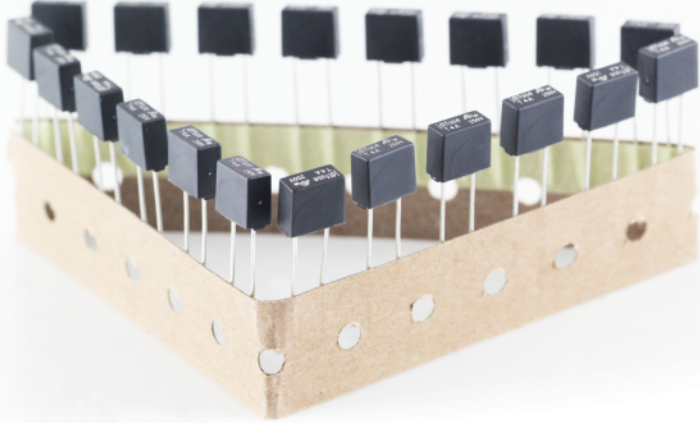

Description

JFS series is Time-Lag type, 250V rated, designed in accordance to IEC 60127-3. This product is suitable for various kinds of electronic machines to work for over current protection.

Features

- Lead-free
- Reduced PCB space requirements
- Direct solderable or plug-in versions
- 100A breaking capacity
- Internationally approved
- Low internal resistance
- Shock safe casing
- Vibration resistant
- Halogen free

Agency Approvals

Agency	File Number
	JDYX2.E486200

Applications

- Battery Chargers
- Consumer Electronics
- Power supplies
- Industrial Controllers

Electrical Characteristics

% of Ampere Rating	Opening Time
210%	2 min Max.
275%	400 ms~10 s
400%	150 ms~3 s
1000%	20 ms~150 ms,

Performance Specification

Amp Code	Rated Current (A)	Voltage Rating (V)	Breaking Capacity	Voltage Drop $1.0 \times I_N$ max. (mV)	Power Dissipation $1.5 \times I_N$ max. (mW)	Melting Integral $10 \times I_N$ min. (A ² s)	Nominal Cold Resistance (Ohms)
0250	0.25	250	25A/250 VAC	260	180	0.036	0.2047
0315	0.315	250	25A/250 VAC	210	205	0.047	0.1836
0400	0.40	250	25A/250 VAC	190	220	0.065	0.1625
0500	0.50	250	25A/250 VAC	170	240	0.083	0.1453
0630	0.63	250	25A/250 VAC	150	260	0.119	0.1240
0800	0.80	250	25A/250 VAC	110	280	3.80	0.0960
1100	1.00	250	25A/250 VAC	115	400	5.80	0.0715
1125	1.25	250	25A/250 VAC	100	500	9.75	0.0569
1160	1.60	250	25A/250 VAC	95	600	13.5	0.0400
1200	2.00	250	25A/250 VAC	90	700	21	0.0298
1250	2.50	250	25A/250 VAC	85	750	32	0.0240
1315	3.15	250	32A/250 VAC	80	1100	55	0.0170
1400	4.00	250	40A/250 VAC	75	1200	100	0.0128
1500	5.00	250	50A/250 VAC	70	1000	90	0.0101
1630	6.30	250	63A/250 VAC	65	1200	126	0.0077
1800	8.00	250	80A/250 VAC	40	1500	150	0.0051
2100	10.0	250	100A/250 VAC	35	2000	205	0.0036
2120	12.0	250	100A/250 VAC	30	2300	218	0.0028
2150	15.0	250	100A/250 VAC	25	2500	226	0.0016

Note: 1.00 means the number one with two decimal places. 1,000 means the number one thousand.

Temperature Derating Curve

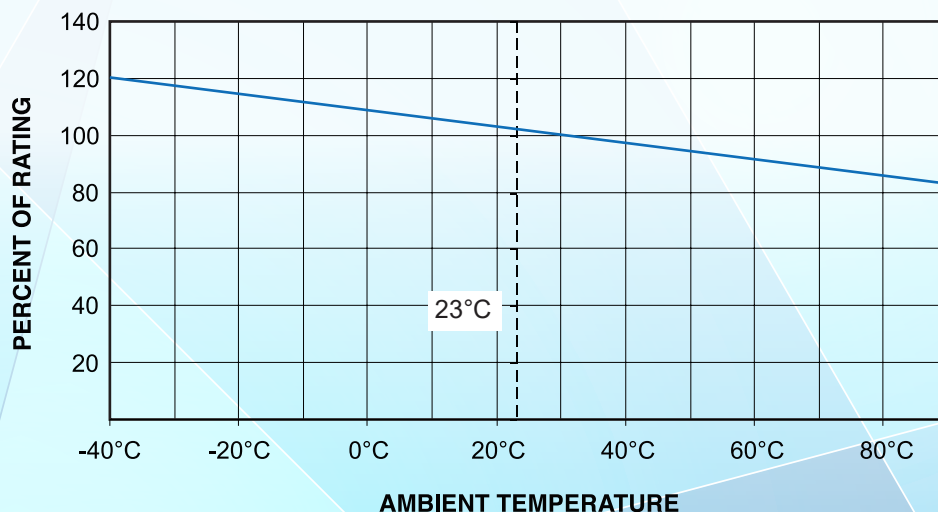

Time-Current Characteristics

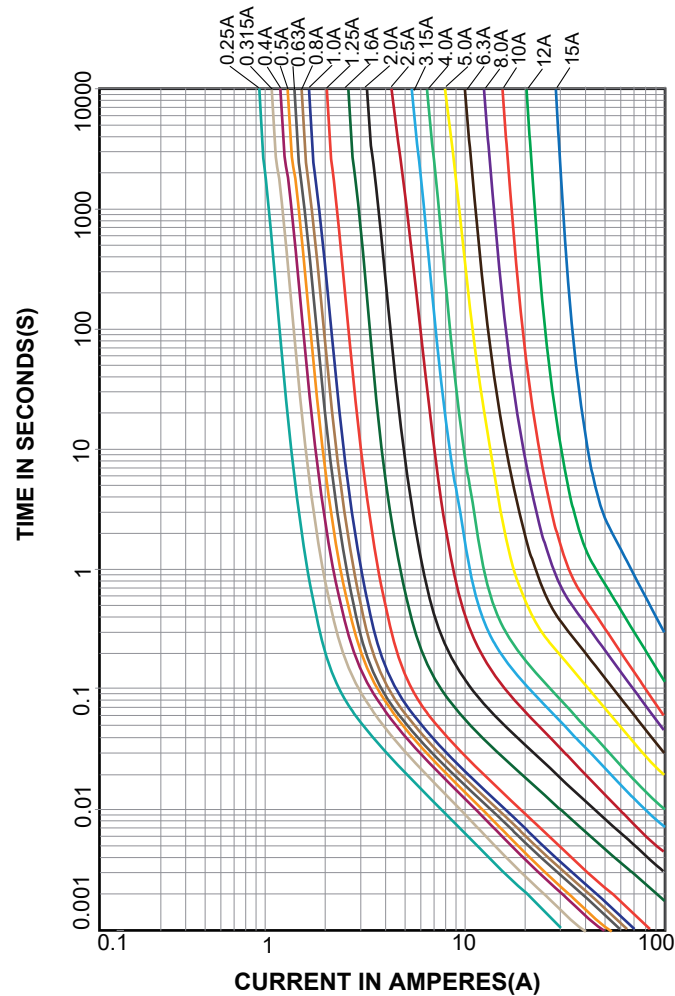

Soldering Parameters

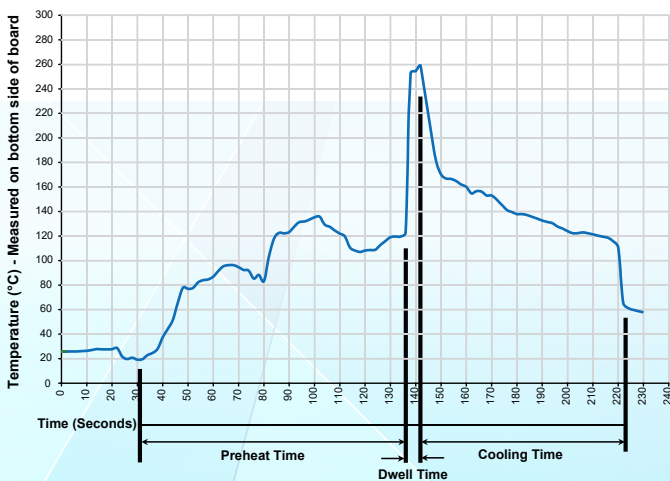

Recommended Process Parameters:

Wave Parameter	Lead-Free Recommendation
Preheat: (Depends on Flux Activation Temperature)	(Typical Industry Recommendation)
Temperature Min.	100° C
Temperature Max.	150° C
Preheat Time	60-180 seconds
Solder Pot Temperature	260° C Maximum
Solder Dwell Time	2-5 seconds

Recommended Hand-Solder Parameters:

Solder Iron Temperature: 350° C +/- 5° C
 Heating Time: 5 seconds max.

Note: These devices are not recommended for IR or Convection Reflow process.

Product Characteristics

Lead Pull Strength	10 N (EN 60068-2-21)
Solderability	260°C, ≤ 3s. (Wave); 350°C, ≤ 1s. (Soldering Iron)
Soldering Heat	260°C, 10s. (IEC 60068-2-20)
Resistance	350°C, 3s. (Soldering Iron)
Operating Temperature	*-40°C to +125°C (consider de-rating)
Climatic Category	-40°C to +85°C /21 days (EN 60068-1,-2-1,-2-2,-2-78)
Stock Conditions	+10°C to +60°C
Vibration Resistance	RH ≤ 75% yearly average, without dew, maximum value for 30 days–95% 24 cycles at 15 min. each(EN 60068-2-6) 10 - 60 Hz at 0.75 mm amplitude; 60 - 2000 Hz at 10 g acceleration * Internal test conditions from thermal cycling at 125°C

Dimensions

Unit: mm

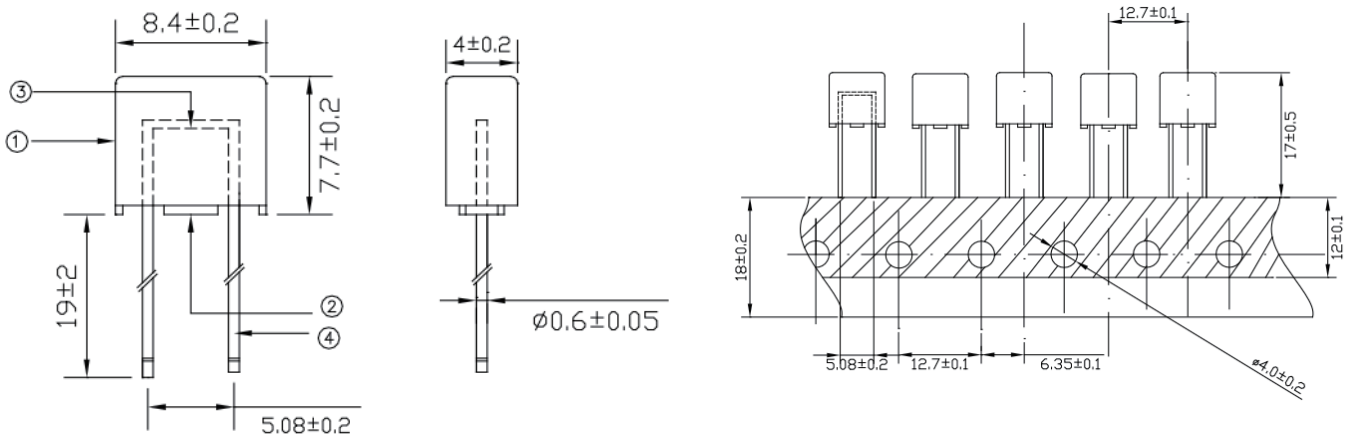

Material Details

No.	Part Name	Material
①	Case	Thermoplastic Nylon
②	Base	Thermoplastic Nylon
③	Fuse element	Alloy
④	Lead wire	Tinned copper wire
⑤	Solder	Solder wire(Sn:99.3%;Cu:0.7%)

Part Number System

JFS xxxx T R

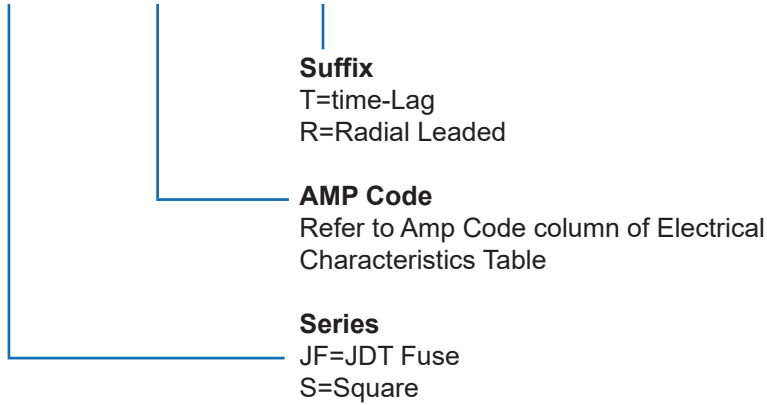

Packaging

Packaging Option	Quantity/Packaging Code
Tape	1,400 pcs/tape
Bag	1,000 pcs/bag